

NUKBB29BSA-TSBBBLK

B.B. TECHNICAL MANUAL
EXTERNAL BB FOR BSA FRAME W/ DUB CRANKSET

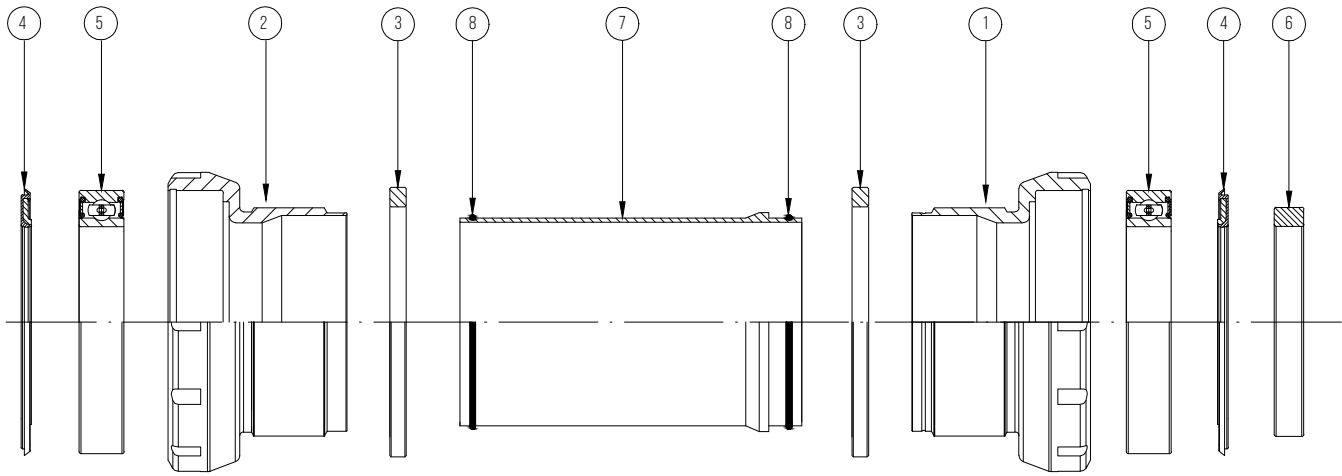
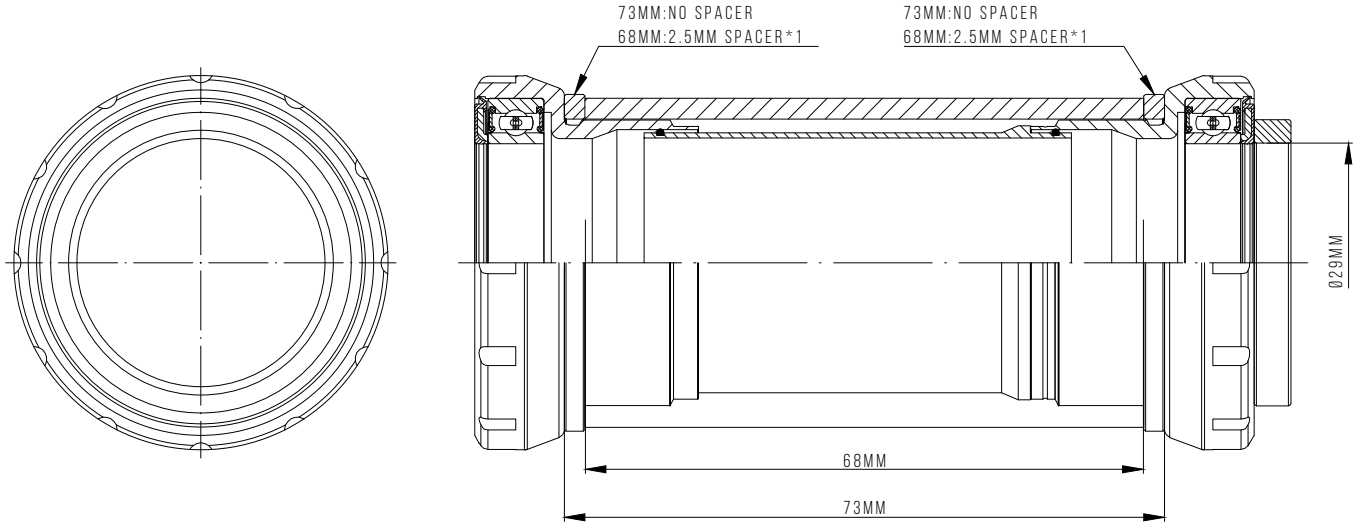

- FOR BSA (1.37"X24T) FRAME & SRAM DUB CRANKSET
- PRECISION CNC ALLOY CUPS
- HAND ASSEMBLED

NUKEPROOF SUGGEST TAKING YOUR BIKE TO AN AUTHORISED NUKEPROOF RETAILER TO HAVE YOUR BOTTOM BRACKET PROFESSIONALLY INSTALLED.

BEFORE RIDING, CHECK THERE IS NO SIDE TO SIDE MOVEMENT IN THE BOTTOM BRACKET AND THAT YOUR CRANKS SPIN SMOOTHLY. IF THERE IS PLAY, HAVE YOUR BIKE INSPECTED BY AN AUTHORISED NUKEPROOF RETAILER TO DETERMINE THE CAUSE OF THIS. CRANK BOLTS SHOULD ALSO BE REGULARLY CHECKED TO ENSURE THEY ARE TIGHT AND CRANKS ARE SECURE.

NEVER USE A HIGH PRESSURE WATER JET WHEN CLEANING AS THIS WILL DAMAGE SEALS AND BEARINGS.

READ MARKINGS FOR CUPS FOR NECESSARY INSTALLATION INFORMATION.

L CUP IS NON DRIVE SIDE
R CUP IS DRIVESIDE

"LIMITED WARRANTY"

NUKEPROOF WARRANTS THIS PRODUCT TO BE FREE FROM DEFECTS IN MATERIALS AND WORKMANSHIP FOR A PERIOD OF TWO YEARS FROM THE DATE OF ORIGINAL RETAIL PURCHASE. THIS WARRANTY IS EXTENDED ONLY TO THE ORIGINAL OWNER OF THE PRODUCT. PROOF OF PURCHASE IS REQUIRED FOR ANY WARRANTY SERVICE, SO BE SURE TO KEEP YOUR RECEIPT.

FOR FULL WARRANTY TERMS AND CONDITIONS VISIT [HTTP://NUKEPROOF.COM/WARRANTY/](http://NUKEPROOF.COM/WARRANTY/)

THANK YOU FOR CHOOSING NUKEPROOF.

NO.	ITEM	QTY
1	BB CUP R	1
2	BB CUP L	1
3	2.5MM SPACER	2
4	OUTBOARD SEAL	2
5	BEARING	2
6	4.5MM SPACER	1
7	CENTER SLEEVE	1
8	O-RING	2